



TOTAL WEIGHING SOLUTION™

KK-30 PR | Bench Scale



Panasonic Kenko Electric. Co.Ltd

(株)デジアイス



FEATURES

- 150 and 300 lb capacities
- Battery or AC operated (AC Adapter Included)
- Tilt and swivel head
- Check Weigh Function (Low/OK/High)
- Counting Feature (Not Legal for Trade)
- RS-232C Interface
- Legal for Trade - COC #98-085

Warranty - Two Years



LIT: FG-K 01/08

Three Types of Display



Large LCD Display



Large VFD Display



Large VFD Display with Printer

PLATFORM SCALES



Weight capacity (kg)	30	60	150	60	150	200
Min. display (kg)	0.01*	0.02*	0.05*	0.02*	0.05*	0.05*
	0.005	0.01	0.02	0.01	0.02	0.02
	0.002	0.005	0.01	0.005	0.01	0.01
Weight capacity (lb)	60	150	300	150	300	400
Min. display (lb)	0.02*	0.05*	0.1*	0.05*	0.1*	0.1*
	0.01	0.02	0.05	0.02	0.05	0.05
	0.005	0.01	0.02	0.01	0.02	0.02
Weight capacity (oz)	960	2400	4800	2400	4800	6400
Min. display (oz)	0.5*	1*	2*	1*	2*	2*
	0.2	0.5	1	0.5	1	1
	0.1	0.2	0.5	0.2	0.5	0.5
No. of samples	5 (can be changed to 10, 20, 50 or 100) pieces					
Max. counts	120,000 pcs	96,000 pcs	120,000 pcs	96,000 pcs	120,000 pcs	160,000 pcs
Min. unit weight	0.25 g	0.625 g	1.25 g	0.625 g	1.25 g	1.25 g
Repeatability (Std. deviation)	0.05 kg	0.01 kg	0.02 kg	0.01 kg	0.02 kg	0.02 kg
Linearity error	0.01 kg	0.02 kg	0.05 kg	0.02 kg	0.05 kg	0.05 kg
Sensitivity drift	20 ppm / C (10 °C~ 30 °C / 50 °F~ 86 °F)					
Display	7 segment LCD display (Character height 26 mm)					
Display update	10 times per second					
Operating temp	- 10 °C~40 °C / 14 °F~104 °F, less than 85% RH (no condensation)					
Power supply	AC adapter or C size (R14P / LR14) x 4 batteries					
Battery operating	Approximately 150 hours with alkaline dry cell battery					
Weighing pan size	300 x 380 mm / 11.8 x 15.0 inches			390 x 530 mm / 15.4 x 20.9 inches		
Dimension	FG-KAM: 300(W) x 624(D) x 781(H) mm / FG-KBM: 380(W) x 464(D) x 118(H) mm			390(W) x 771(D) x 781(H) mm		
Weight (approximately)	FG-KAM: 11.2 kg / FG-KBM: 9.7 kg			16.4 kg		
Calibration weight (Factory setting)	30 kg / 60 lb	60 kg / 150 lb	150 kg / 300 lb	60 kg / 150 lb	150 kg / 300 lb	200 kg / 400 lb

* Legal for Trade Setting

- Battery life: Up to 80 hours when back light off, up to 35 hours with backlight on

Display

- Choice of Integral or customer tower display
- Back lit front & rear LCD as standard
- Back light programmable for power saving
- Characters 20mm in height
- Unit weight: 6 seven segment digits
- Unit price: 6 seven segment digits
- Total price: 6 seven segment digits

Power Supply

- Power operation via plug in switch mode power supply 100-240V
- Battery operation via internal rechargeable 6V 4amp sealed lead acid battery

Operating Range

- Operating temperature: 14°F - 104°F (-10°C to +40°C)

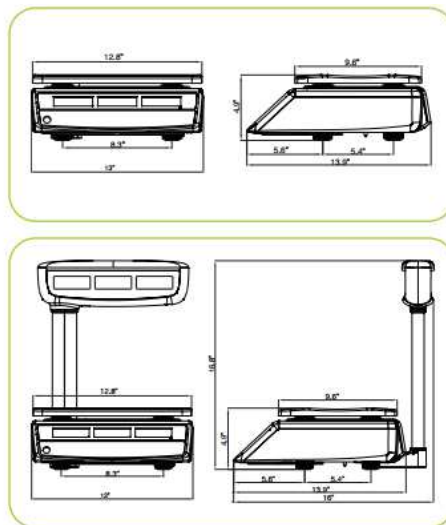

Model Selection Guide

Capacity	Column	Pan Size	Model Number
30kg / 60lb	No	M	FG-30KBM
30kg / 60lb	Yes	M	FG-30KAM
60kg / 150lb	No	M	FG-60KBM
60kg / 150lb	Yes	M	FG-60KAM
60kg / 150lb	Yes	L	FG-60KAL
150kg / 300lb	No	M	FG-150KBM
150kg / 300lb	Yes	M	FG-150KAM
150kg / 300lb	Yes	L	FG-150KAL
200kg / 400lb	Yes	L	FG-200KAL



Panasonic Kenko Electric Co, Ltd

36 Sisenju, Okio, Osaka 234-23354 Japan

Tel. 81-32-565434667

Specifications subject to change without notice



...Clearly a Better Value

Specifications subject to change without notice